

REVISIONS		
REV	DESCRIPTION	DATE

8	MMC92185A585	2	AHCS 5/16"UNC X 1.25"	316 SS
7	MMC93190A591	2	HEX BOLT 5/16" UNC X 2"	316 SS
6		1	CLEVIS PIN 3/4"	STEEL
5	LR M64 x 2	2	ENIDINE LOCK RING	STEEL
4	OEM 2.0M x 4 CM(S)	1	ENIDINE DAMPER	STEEL
3	RBC1103002	2	DAMPER MOUNT SPACER	A36 STEEL
2	RBC1103003	1	ROD EYE	304 SS
1	RBC1103001	1	DAMPER MOUNT	A36 STEEL
ITEM	DWG / PART NO.	QTY	DESCRIPTION	MATERIAL

STANDARD TOLERANCES UNLESS OTHERWISE SPECIFIED				
FRAC	ANG	X	XX	XXX
± 1/64"	± 0.5°	± 0.01"	± 0.01"	± 0.005"
FINISH 125√ UNLESS SPECIFIED REMOVE BURRS AND SHARP EDGES				

TITLE DAMPERASSEMBLY			DWG NO. RMB1103004			
DRAWN R. BEAUMONT	DATE 10-MAR-2011	DRAWN FOR: DR. MICK PETERSON BIOLOGICALLY APPLIED ENGINEERING ORONO, MAINE				
APPROVED M. PETERSON	10-MAR-2011	PROJ.NO. 2011P03	SIZE A	SCALE 1:20	REV -	
MFG AWM	MAR-2011				SHEET 1 OF 1	

NOTE:
 1) IF REQUIRED, REMOVE JAM NUT ON SPRING TENSIONER AND USE ROD EYE FOR JAM.
 2) PRE-ASSEMBLE DAMPER MOUNT AND DAMPER USING EXISTING BOLT HOLES.
 3) USE DAMPER MOUNT AS A TEMPLATE TO DRILL (2) NEW HOLES, 5/16" UNC, THRU BASE PLATE.

CONFIDENTIAL! THIS DOCUMENT CONTAINS TRADE SECRET AND CONFIDENTIAL INFORMATION, AND IS THE PROPERTY OF ALEXANDER'S WELDING AND MACHINE, AND IS TRANSMITTED TO THE RECEIVER IN CONFIDENCE. THE RECEIVER BY RECEIVING AND RETAINING THIS DRAWING ACCEPTS IT IN CONFIDENCE AND AGREES THAT IT WILL NOT USE THE TRADE SECRET OR CONFIDENTIAL INFORMATION THEREIN, WILL NOT DISCLOSE TO OTHERS EITHER THE DRAWING OR THE CONFIDENTIAL INFORMATION THEREIN.

ALEXANDER'S WELDING AND MACHINE
 GREENFIELD TWP, MAINE 207-827-3300



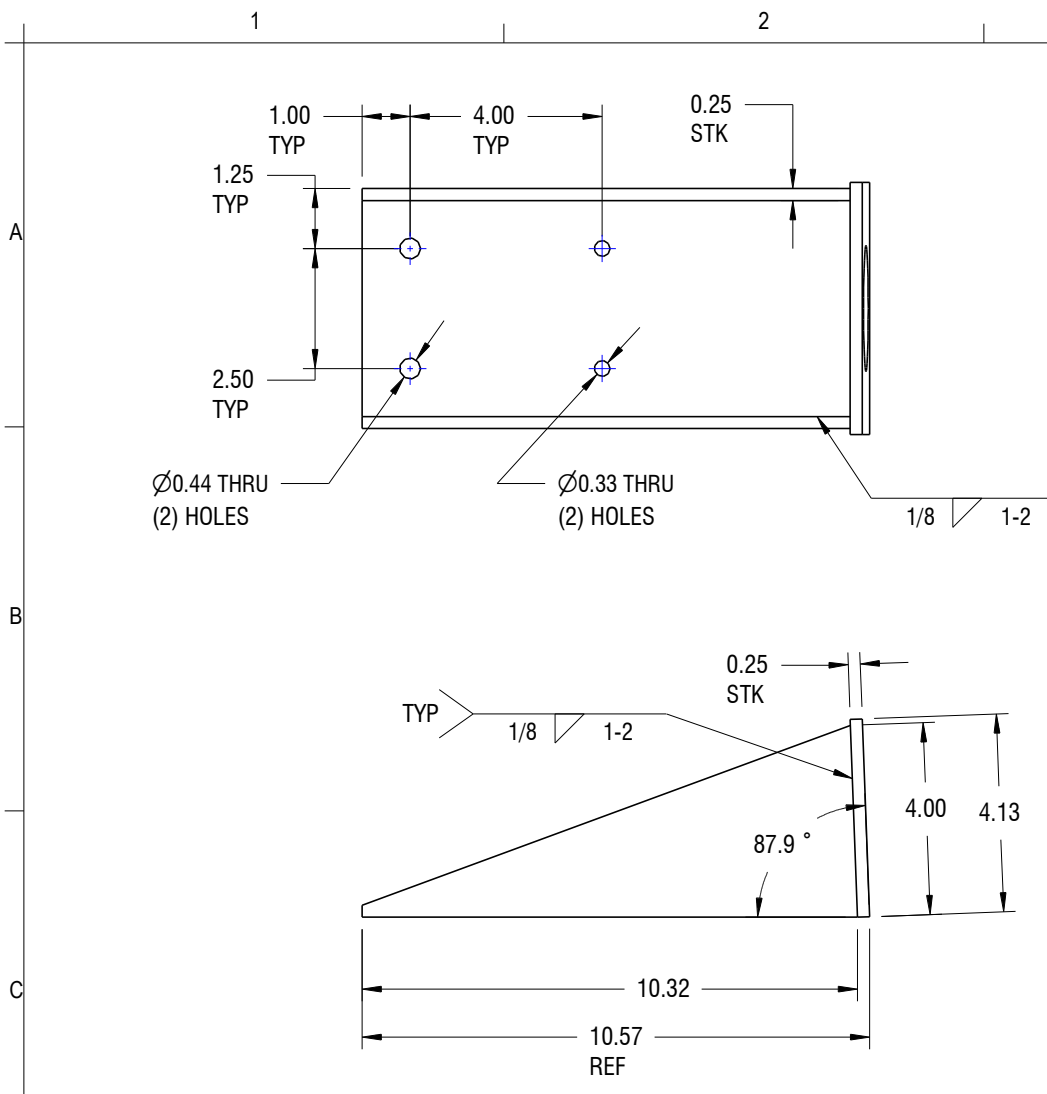

REVISIONS		
REV	DESCRIPTION	DATE
A	MODIFIED OVERALL DIMENSIONS, RELEASE FOR FAB	10-MAR-2011

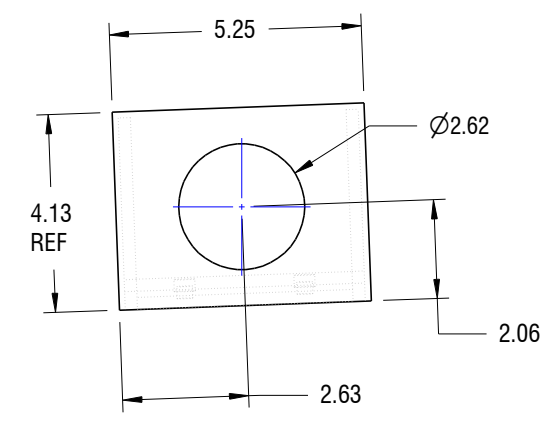
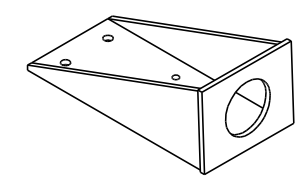

- NOTE:
- 1) MATERIAL: ASTM A36 PLATE, 1/4"
 - 2) WEIGHT: 7.5 LB
 - 3) PAINT BLACK, 2 COATS

STANDARD TOLERANCES UNLESS OTHERWISE SPECIFIED					TITLE DAMPER MOUNT		DWG NO. RBC1103001				
FRAC	ANG	X	XX	XXX	DRAWN R. BEAUMONT	DATE 03-MAR-2011	DRAWN FOR: DR. MICK PETERSON BIOLOGICALLY APPLIED ENGINEERING ORONO, MAINE				
± 1/64"	± 0.5°	± 0.01"	± 0.01"	± 0.005"	APPROVED M. PETERSON	10-MAR-2011					
FINISH 125 UNLESS SPECIFIED REMOVE BURRS AND SHARP EDGES					MFG AWM	MAR-2011	PROJ NO. 2011P03	SIZE A	SCALE 1:4	REV A	SHEET 1 OF 1

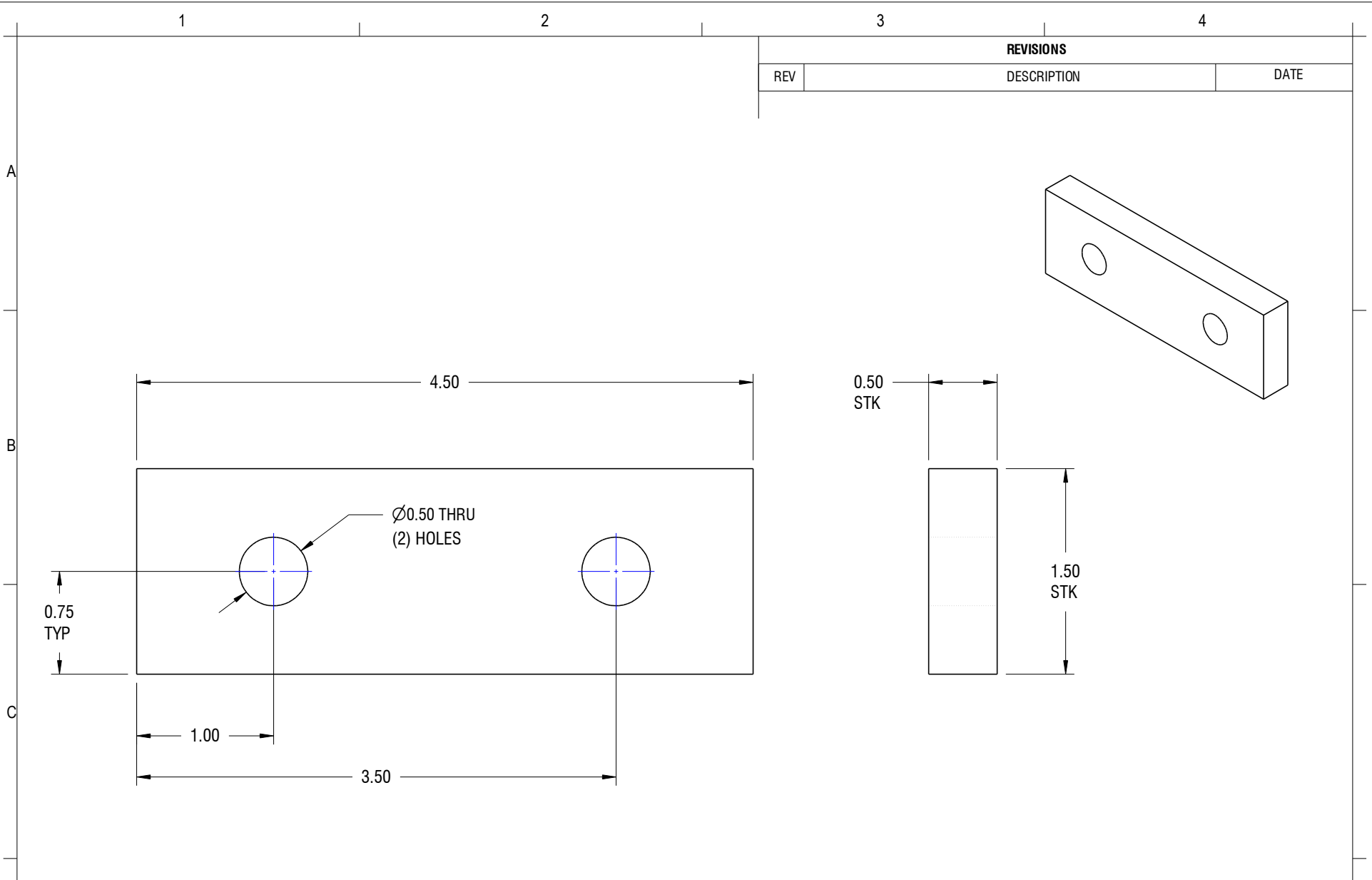

REVISIONS		
REV	DESCRIPTION	DATE

NOTE:

- 1) MATERIAL: ASTM A36 BAR, 1.5" X 0.5"
- 2) WEIGHT: 0.5 LB
- 3) PAINT BLACK, 2 COATS

TITLE DAMPER MOUNT SPACER			DWG NO. RMB1103002					
DRAWN R. BEAUMONT		DATE 10-MAR-2011		DRAWN FOR: DR. MICK PETERSON BIOLOGICALLY APPLIED ENGINEERING ORONO, MAINE				
APPROVED M. PETERSON		10-MAR-2011						
MFG AWM		MAR-2011		PROJ NO. 2011P03	SIZE A	SCALE 1:1	REV -	SHEET 1 OF 1

STANDARD TOLERANCES UNLESS OTHERWISE SPECIFIED				
FRAC	ANG	X	XX	XXX
± 1/64"	± 0.5°	± 0.01"	± 0.01"	± 0.005"
FINISH 125 $\sqrt{\text{V}}$ UNLESS SPECIFIED REMOVE BURRS AND SHARP EDGES				

CONFIDENTIAL! THIS DOCUMENT CONTAINS TRADE SECRET AND CONFIDENTIAL INFORMATION, AND IS THE PROPERTY OF ALEXANDER'S WELDING AND MACHINE, AND IS TRANSMITTED TO THE RECEIVER IN CONFIDENCE. THE RECEIVER BY RECEIVING AND RETAINING THIS DRAWING ACCEPTS IT IN CONFIDENCE AND AGREES THAT IT WILL NOT USE THE TRADE SECRET OR CONFIDENTIAL INFORMATION THEREIN; WILL NOT DISCLOSE TO OTHERS EITHER THE DRAWING OR THE CONFIDENTIAL INFORMATION THEREIN.

ALEXANDER'S WELDING AND MACHINE
GREENFIELD TWP, MAINE 207-827-3300



REVISIONS		
REV	DESCRIPTION	DATE

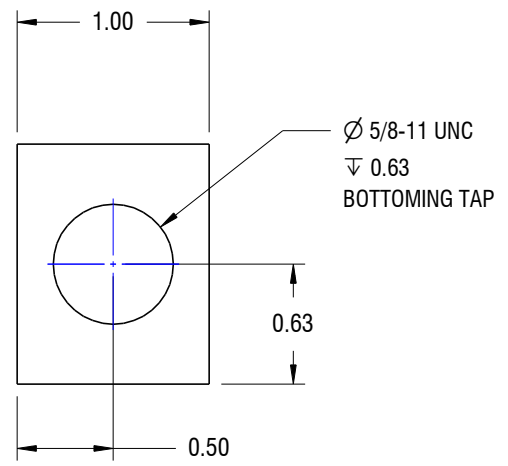
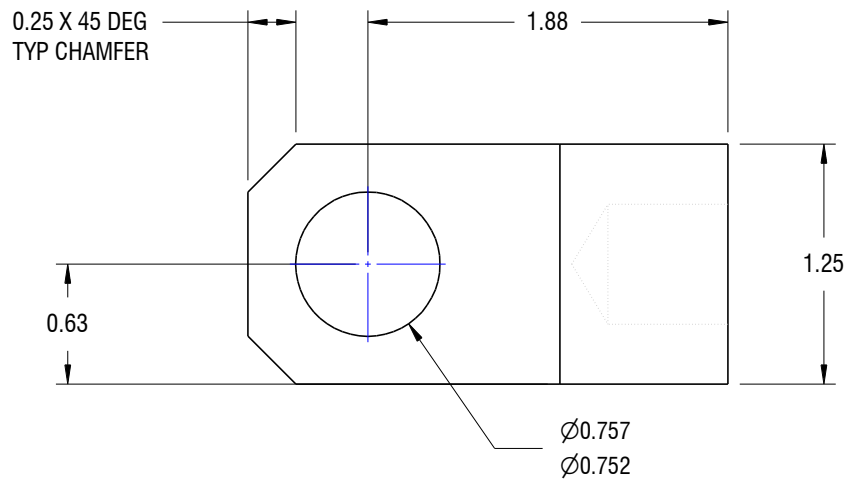
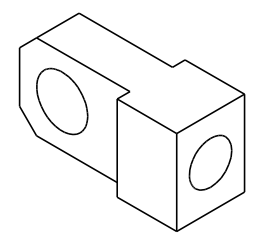
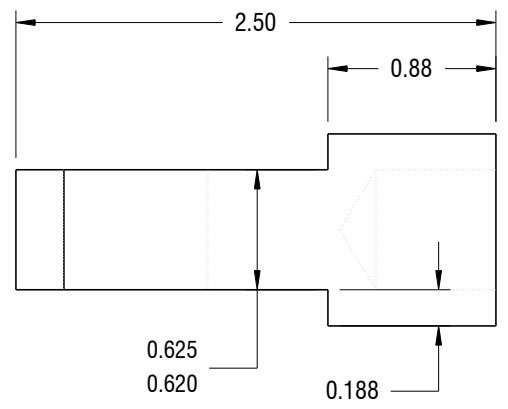

NOTE:

- 1) MATERIAL: 304 OR 316 SS
- 2) WEIGHT: 0.5 LB

TITLE ROD EYE				DWG NO. RMB1103003					
DRAWN R. BEAUMONT		DATE 10-MAR-2011		DRAWN FOR: DR. MICK PETERSON BIOLOGICALLY APPLIED ENGINEERING ORONO, MAINE					
APPROVED M. PETERSON		10-MAR-2011		PROJ NO. 2011P03		SIZE A	SCALE 1:1	REV -	SHEET 1 OF 1
MFG AWM		MAR-2011							

STANDARD TOLERANCES UNLESS OTHERWISE SPECIFIED				
FRAC	ANG	X	XX	XXX
± 1/64"	± 0.5°	± 0.01"	± 0.01"	± 0.005"
FINISH 125 $\sqrt{\text{V}}$ UNLESS SPECIFIED REMOVE BURRS AND SHARP EDGES				



Enidine Adjustable Hydraulic Series shock absorbers offer the most flexible solutions to energy absorption application requirements when input parameters vary or are not clearly defined.

By simply turning an adjustment knob, the damping force can be changed to accommodate a wide range of conditions. Enidine offers the broadest range of adjustable shock absorbers and mounting accessories in the marketplace today.

The Enidine **OEMXT Series** provides a low profile adjustment knob offered in metric or imperial thread configurations with stroke lengths of 25 to 150 mm for drop-in competitive interchange. **Low Range (LROEMXT) Series** products are also available to control velocities as low as 0,08 m/s and propelling forces as high as 17 790 N. OEMXT and OEM Large Series shock absorbers are fully field repairable.

Features and Benefits

- Adjustable design lets you “fine-tune” your desired damping and lock the numbered adjustment setting.
- Internal orifice design provides deceleration with the most efficient damping characteristics, resulting in the lowest reaction forces in the industry.
- Threaded cylinders provide mounting flexibility and increased surface area for improved heat dissipation.
- Incorporated optional fluids and seal packages can expand the standard operating temperature range from (-10°C to 80°C) to (-30°C to 100°C)
- ISO quality standards result in reliable, long-life operation.
- Operational parameters can be expanded through the use of Enidine’s Low Range and High Performance products.
- Fully field repairable units are available in mid-bore and larger bore product ranges.
- Custom orificed non-adjustable units (CBOEM) can be engineered to meet specific application requirements.
- A select variety of surface finishes maintains original quality appearance and provides the longest corrosion resistance protection.

Adjustable Series Hydraulic Shock Absorbers

OEM Series

Overview

Enidine Adjustable Single Orifice Shock Absorbers

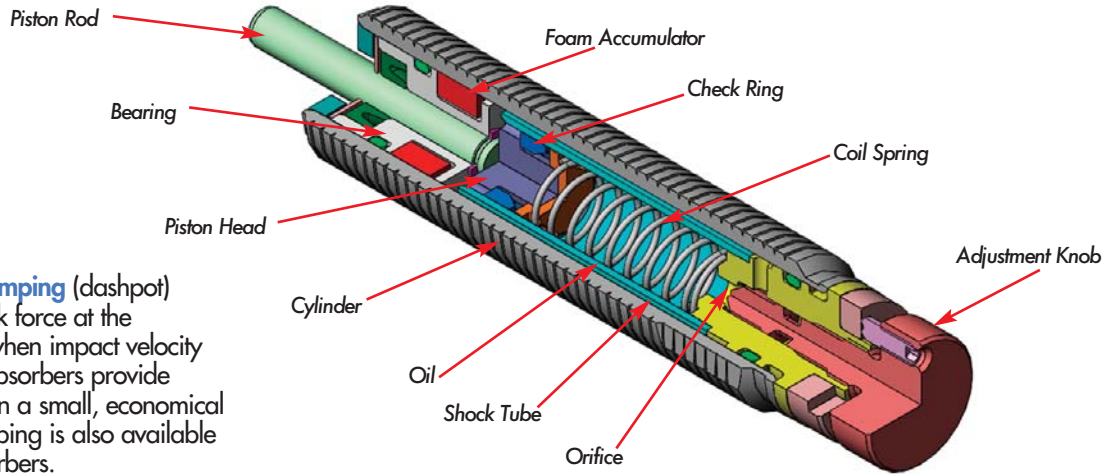
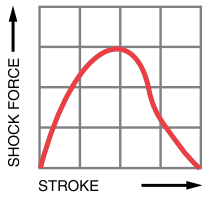

Constant orifice area damping (dashpot) provides the largest shock force at the beginning of the stroke when impact velocity is highest. These shock absorbers provide high-energy absorption in a small, economical design. This type of damping is also available in adjustable shock absorbers.

The damping force of an Enidine single orifice shock absorber can be changed by turning the adjustment knob. Maximum damping force is achieved by turning the adjustment knob to eight (8), while minimum damping force is achieved by turning the adjustment knob to zero (0). Turning the adjustment knob causes the adjustment ball to increase or decrease the clearance (orifice area) between the ball and its seat, depending on rotation direction.

The internal structure of an adjustable single orifice shock absorber is shown above. When force is applied to the piston rod, the check ball is seated and the valve remains closed.

Oil is forced out of the high pressure shock tube chamber through the orifice, creating internal pressure allowing smooth, controlled deceleration of the moving load. When the load is removed, the compressed coil spring moves to reposition the piston head, the check ball unseats, opening the valve that permits rapid piston rod return to the original extended position. The closed cellular foam accumulator compensates for fluid displaced by the piston rod during compression and extension. Without the fluid displacement volume provided by the foam accumulator, the closed system would be hydraulically locked. This type of orifice design results in.

Enidine Adjustable Multiple Orifice Shock Absorbers

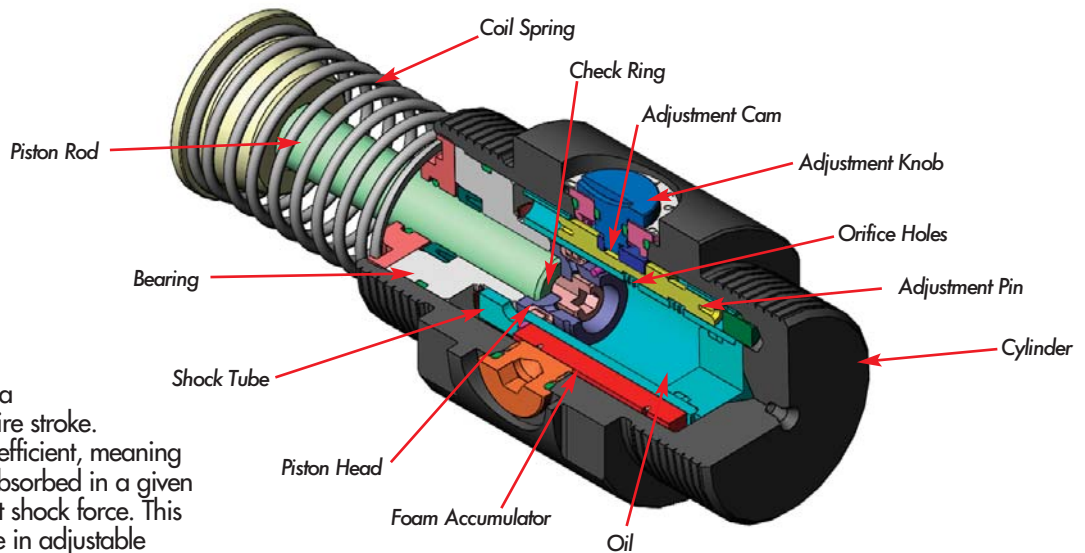
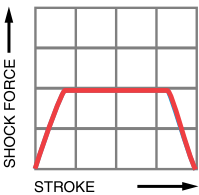

Conventional damping allows linear deceleration by providing a constant shock force over the entire stroke. This standard design is the most efficient, meaning it allows the most energy to be absorbed in a given stroke, while providing the lowest shock force. This type of damping is also available in adjustable shock absorbers.

The adjustable multiple orifice shock absorber is similar to the principles described earlier. The check ring replaces the check ball and the adjustment feature uses an adjustment pin instead of an adjustment ball. The damping force of the shock absorber can be changed by turning the adjustment knob. Maximum damping force is achieved by turning the adjustment knob to eight (8), while minimum damping force is achieved by turning the adjustment knob to zero (0).

Turning the adjustment knob rotates the adjustment cam within the shock absorber. The cam, in turn, moves the adjustment pin in the shock tube, closing or opening the orifice holes. By closing the orifice holes, the total orifice area of the shock absorber is reduced, thus increasing the damping force of the shock absorber. The adjustable shock absorber enables the user to change the damping force of the unit, should input conditions change, while still maintaining a conventional-type damping curve. Low velocity range (LR) series configurations are available for controlling velocities that fall below the standard adjustable range.

After properly sizing the shock absorber, the useable range of adjustment settings for the application can be determined:

1. Locate the intersection point of the application's impact velocity and the selected model graph line.
2. The intersection is the **maximum** adjustment setting to be used. Adjustments **exceeding this maximum suggested setting could overload the shock absorber.**
3. The useable adjustment setting range is from the 0 setting to the **maximum** adjustment setting as determined in step 2.

Example: OEM 1.25M x 1

1. Impact Velocity: 1,0 m/s
2. Intersection Point: Adjustment Setting 5
3. Useable Adjustment: Setting Range 0 to 5

Example: (LR)OEMXT 2.0M x 2

1. Impact Velocity: .5 m/s
2. Intersection Point: Adjustment Setting 3
3. Useable Adjustment: Setting Range 0 to 3

Useable Adjustment Setting Range

Position 0 provides minimum damping force.
Position 8 provides maximum damping force.

OEMXT Large

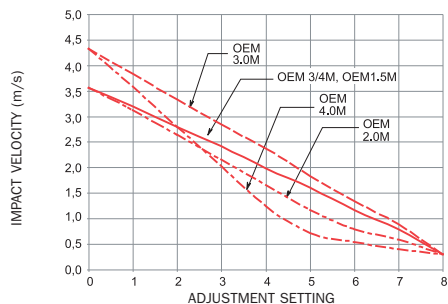

180° adjustment with setscrew locking. OEMXT 3.0M – OEM 4.0M



360° adjustment with setscrew locking. OEMXT 1.5M and OEMXT 2.0M

(LR)OEMXT Large

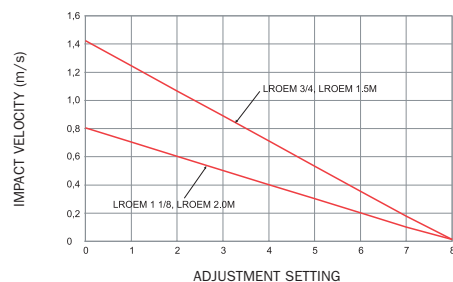

360° adjustment with setscrew locking (LR)OEMXT 1.5M and (LR)OEMXT 2.0M

Platinum OEM Small Series

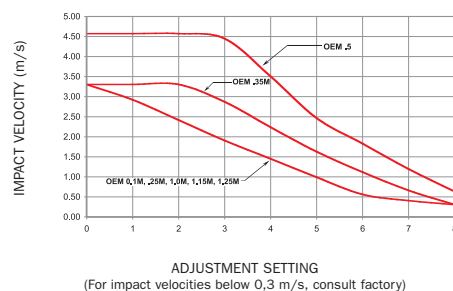

180° adjustment with setscrew locking OEM 0.1M - OEM 0.5M



360° adjustment with setscrew locking OEM 1.0M

Platinum (LR)OEM Small Series

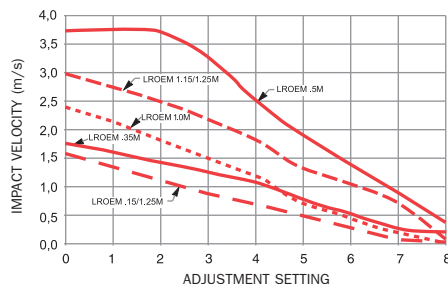

180° adjustment with setscrew locking (LR)OEM 0.15M - (LR)OEM 0.5M



360° adjustment with setscrew locking (LR)OEM 1.0M

Adjustable Series Hydraulic Shock Absorbers

OEM Series

Ordering Information/Application Worksheet

Shock Absorbers

10

Select quantity

OEM 1.0M

- Select catalog number:
- OEM, HP (Adjustable)
 - LROEM (Low range adjustable)
 - CBOEM (Non-adjustable)
 - AOEM/LRAOEM (Adjustable and low range adjustable air/oil return)
 - CBAOEM (Non-adjustable air/oil return)

B

- Select piston rod type:
- " " (No button)
 - "B" (Button model, OEM 0.1M, .25M, .35M, .5M and 1.0M only)
 - "CM" (Clevis Mount)
 - "CMS" (Clevis Mount with Spring)

Application Data

- Required for Engineered CBOEM and CBAOEM models only:
- Vertical or Horizontal motion
 - Weight
 - Impact velocity
 - Propelling force (if any)
 - Other (temperature or other environmental conditions)
 - Cycles per hour

Shock Absorber Accessories

Example 1

10

Select quantity

LR M42 x 1.5

(P/N F82940049)

Select catalog or part number

Lock Ring

Example 2

5

Select quantity

UC 2940

(P/N C92940079)

Select catalog or part number

Urethane Striker Cap

Application Worksheet

FAX NO.: _____

DATE: _____

ATTN: _____

COMPANY: _____

The Enidine Application Worksheet makes shock absorber sizing and selection easier.

Fax, phone, or mail worksheet data to Enidine headquarters or your nearest Enidine subsidiary/affiliate or distributor. (See catalog back cover for Enidine locations, or visit www.enidine.eu for a list of Enidine distributors.)

Upon Enidine's receipt of this worksheet, you will receive a detailed analysis of your application and product recommendations. (For custom design projects, Enidine representatives will consult with you for specification requirements.)

GENERAL INFORMATION

CONTACT: _____

DEPT/TITLE: _____

COMPANY: _____

ADDRESS: _____

TEL: _____ FAX: _____

EMAIL: _____

PRODUCTS MANUFACTURED: _____

APPLICATION DESCRIPTION

Motion Direction (Check One):

Horizontal Vertical Up Incline Angle _____
 Down Down Height _____

Rotary Horizontal Rotary Vertical Up
 Down

Weight (Min./Max.): _____ (Kg)

Cycle Rate _____ (cycles/hour)

Additional Propelling Force (If known) _____ (N)

Air Cyl: Bore _____ (mm) Max. Pressure _____ (bar) Rod Dia. _____ (mm)

Hydraulic Cyl: Bore _____ (mm) Max. Pressure _____ (bar)
 Rod Dia. _____ (mm)

Motor _____ (kW) Torque _____ (Nm)

Ambient Temp. _____ (°C)

Environmental Considerations: _____

SHOCK ABSORBER APPLICATION

(All Data Taken at Shock Absorber)

Number of Shock Absorbers to Stop Load _____

Impact Velocity (min./max.) _____ (m/s)

Shock Absorber Stroke Requirements: _____ (mm)

(a) Load Requirements _____ (m/s²)

RATE CONTROL APPLICATION

(All Data Taken at Rate Control)

Number of Rate Controls to Control the Load _____

Control Direction: Tension (T) Compression (C)

Required Stroke: _____ (mm) Est. Stroke Time _____ (s)

Estimated Velocity at the Rate Control _____ (m/s)

Adjustable Series Hydraulic Shock Absorbers

OEM Small Bore Series

Technical Data

OEM 0.1M → (LR)OEM 1.0M Series

Standard

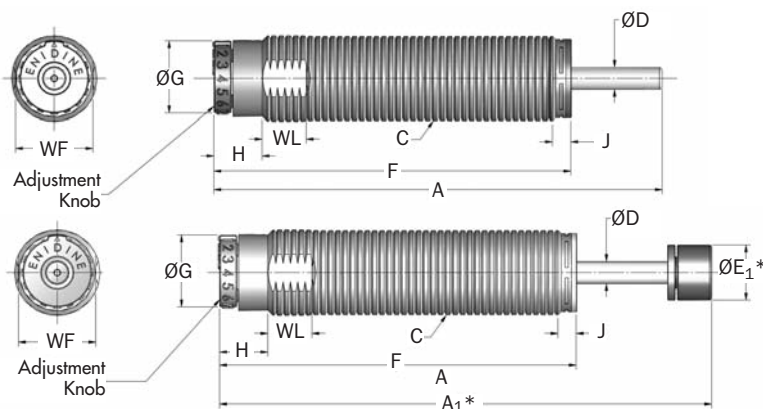
*Note: A₁ and E₁ apply to button models.

Catalog No./ Model	(S) Stroke mm	Optimal Velocity Range m/s	E _T Max. Nm/c	E _T C Max. Nm/hr	F _p Max. Reaction Force N	Nominal Coil Spring Force		F _D Max. Propelling Force N	Mass g
						Extended N	Compressed N		
OEM .1M (B)	7,0	0,3-3,30	6,0	12 400	1 220	2,2	4,5	350	28
OEM .15M (B)	10,0	0,3-3,30	6,0	19 000	890	3,5	7,5	350	56
OEM .25M (B)	10,0	0,3-3,30	6,0	20 000	890	3,5	7,5	350	56
LROEM .25M (B)	10,0	0,08-1,30	6,0	20 000	890	3,5	7,5	440	56
OEM .35M (B)	12,0	0,3-3,30	17,0	34 000	2 000	4,5	9,8	530	85
LROEM .35M (B)	12,0	0,08-1,30	17,0	34 000	2 000	4,5	9,8	890	85
OEM .5M (B)	12,7	0,3-4,50	28,0	32 000	3 500	5,8	12,4	670	141
LROEM .5M (B)	12,7	0,08-1,30	28,0	32 000	3 500	8,9	17,0	1 120	141
OEM 1.0M (B)	25,0	0,3-3,30	74,0	70 000	4 400	13,0	27,0	1 330	285
OEM 1.0MF (B)	25,0	0,3-3,30	74,0	70 000	4 400	13,0	27,0	1 330	285
LROEM 1.0M (B)	25,0	0,08-1,30	74,0	70 000	4 400	13,0	27,0	2 016	285
LROEM 1.0MF (B)	25,0	0,08-1,30	74,0	70 000	4 400	13,0	27,0	2 016	285

Catalog No./ Model	A mm	A ₁ mm	C mm	D mm	E ₁ mm	F mm	G mm	H mm	J mm	WF mm	WL mm
OEM 0.1M (B)	57,0	67,0	M10 x 1.0	3,0	8,6	49,4	8,6	10,2	–	–	–
OEM 0.15M (B)	81,8	91,7	M12 x 1.0	3,3	8,6	71,4	10,9	14,2	–	11,0	9,7
(LR)OEM .25M (B)	81,8	91,2	M14 x 1.5	3,3	11,2	71,4	10,9	14,2	–	12,0	12,7
(LR)OEM .35M (B)	100,6	110,7	M16 x 1.5	4,0	11,2	87,4	11,2	14,5	0,5	14,0	12,7
(LR)OEM .5M (B)	98,6	110,5	M20 x 1.5	4,8	12,7	84,1	16,0	17,0	–	18,0	12,7
(LR)OEM 1.0M (B)	130,0	142,7	M27 x 3.0	6,4	15,7	104,0	22,0	14,0	4,6	23,0	12,7
(LR)OEM 1.0MF (B)	130,0	142,7	M25 x 1.5	6,4	15,7	104,0	22,0	14,0	4,6	23,0	12,7

Notes: 1. All shock absorbers will function satisfactorily at 5% of their maximum rated energy per cycle. If less than 5%, a smaller model should be specified.

2. For mounting accessories, see pages 22-23.

3. (B) indicates button model of shock absorber. Buttons cannot be added to non-button models or removed from button models OEM .1M to OEM 1.0M.

Adjustable Series Hydraulic Shock Absorbers

OEM Small Bore Series

OEM 0.1M → (LR)OEM 1.0M Series

Accessories

Jam Nut (JN)

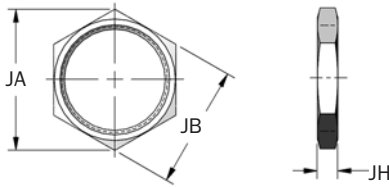

Catalog No./ Model	Part Number	Model Ref	JA mm	JB mm	JH mm	Mass g
JN M10 x 1	J24421167	OEM 0.1M (B)	15,0	13,0	3,2	2
JN M12 x 1	J25588035	OEM .15M (B)	17,0	15,0	4,0	2
JN M14 x 1.5	J23935035	(LR)OEM .25M (B)	19,7	17,0	4,0	3
JN M16 x 1.5	J230844167	(LR)OEM .35M (B)	20,0	19,0	6,0	5
JN M20 x 1.5	J22646035	(LR)OEM .5M (B)	27,7	24,0	4,6	9
JN M27 x 3	J22587167	(LR)OEM 1.0M (B)	37,0	32,0	4,6	15
JN M25 x 1.5	J23004167	(LR)OEM 1.0MF (B)	37,0	32,0	4,6	15

Stop Collar (SC)

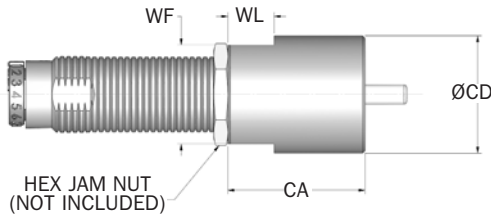

Catalog No./ Model	Part Number	Model Ref	CA mm	CD mm	WF mm	WL mm	Mass g
∅SC M10 x 1	M98921171	OEM 0.1M (B)	19,0	14,0	–	–	11
∅SC M12 x 1	M930289171	OEM 0.15M (B)	19,0	16,0	14,0	9,0	14
∅SC M14 x 1.5	M930281171	(LR)OEM .25M (B)	25,4	19,0	19,0	12,0	28
∅SC M16 x 1.5	M99018170	(LR)OEM .35M (B)	25,4	19,0	–	–	28
∅SC M20 x 1.5	M930282171	(LR)OEM .5M (B)	38,0	25,4	22,0	12,0	63
∅SC M27 x 3	M930283171	(LR)OEM 1.0M (B)	50,8	38,0	32,0	15,0	215
∅SC M25 x 1.5	M930284171	(LR)OEM 1.0MF (B)	50,8	38,0	32,0	15,0	215

Notes: 1. *Do not use with urethane striker cap.
2. ∅ = Non-standard lead time items, contact Enidine.

Universal Retaining Flange (Small Bore) (UF)

UF M10 x 1 → UF M16 x 1,5

UF M20 x 1,5 → UF M27 x 3

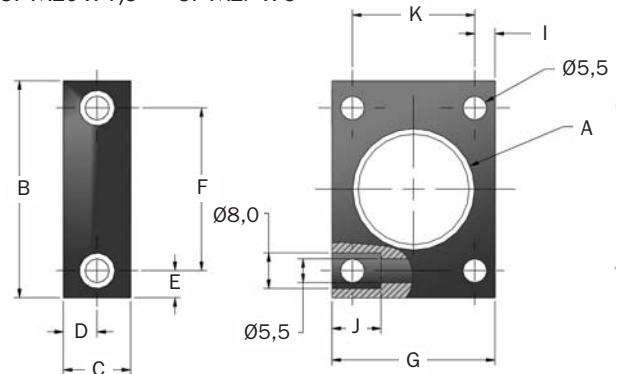
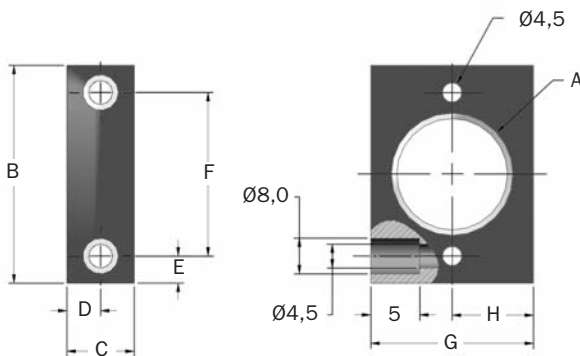

Catalog No./ Model	Part Number	Model Ref	A mm	B mm	C mm	D mm	E mm	F mm	G mm	H mm	I mm	J mm	K mm
∅UF M10 x 1	U16363189	OEM 0.1M (B)	M10 x 1	38,0	12,0	6,0	6,0	25,5	25,0	12,5	–	5	–
∅UF M12 x 1	U15588189	OEM .15M (B)	M12 x 1	38,0	12,0	6,0	6,0	25,5	25,0	12,5	–	5	–
∅UF M14 x 1.5	U13935143	(LR)OEM .25M (B)	M14 x 1,5	45,0	16,0	8,0	5,0	35,0	30,0	15,0	–	5	–
∅UF M16 x 1.5	U19018143	(LR)OEM .35M (B)	M16 x 1,5	45,0	16,0	8,0	5,0	35,0	30,0	15,0	–	–	–
∅UF M20x 1.5	U12646143	(LR)OEM .5M (B)	M20 x 1,5	48,0	16,0	8,0	6,5	35,0	35,0	–	4,75	11,4	25,5
∅UF M25 x 1.5	U13004143	(LR)OEM 1.0MF (B)	M25 x 1,5	48,0	16,0	8,0	6,5	35,0	35,0	–	4,75	11,4	25,5
∅UF M27 x 3	U12587143	(LR)OEM 1.0M (B)	M27 x 3	48,0	16,0	8,0	6,5	35,0	35,0	–	4,75	11,4	25,5

Notes: 1. ∅ = Non-standard lead time items, contact Enidine.
2. All dimensions in millimeters

Adjustable Series Hydraulic Shock Absorbers

OEM Small Bore Series

Accessories

OEM 0.1M → OEM 1.0M Series

Side Load Adaptor (SLA)

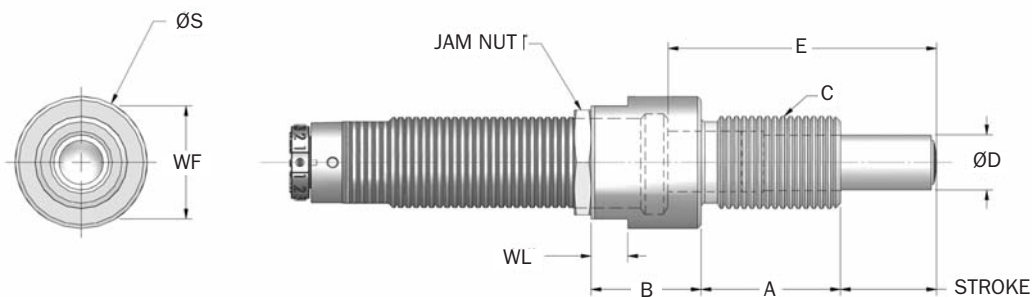

Catalog No./Model	Part Number	Model Ref	Stroke mm	A mm	B mm	C mm	D mm	E mm	S mm	WF mm	WL mm
SLA 10MF	SLA 33457	OEM 0.1M	6,4	12	11	–	5	21,9	13	11	4,0
SLA 12MF	SLA 33299	OEM .15M	10,0	18	14	–	6	32,4	16	13	7,0
△ SLA 14MC	SLA 34756	(LR)OEM .25M	10,0	18	16	M14 x 1,5	8	34,3	18	15	7,0
SLA 16 MC	SLA 34757	(LR)OEM .35M	12,7	20	16	M16 x 1	8	39,2	20	17	7,0
SLA 20 MC	SLA 33262	(LR)OEM .5M	12,7	24	14	M20 x 1,5	11	41,5	25	22	7,0
SLA 25 MF	SLA 33263	(LR)OEM 1.0MF	25,0	38	30	M25 x 1,5	15	73,2	36	32	10,0
SLA 27 MC	SLA 33296	(LR)OEM 1.0M	25,0	38	30	M27 x 3	15	73,2	36	32	10,0

Notes: 1. Maximum sideload angle is 30°.

2. △= Non-standard lead time items, contact Enidine.

Clevis Mount

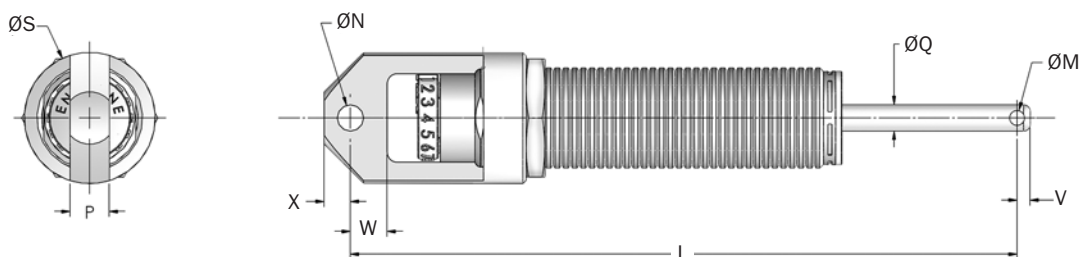

Catalog No./Model	(S) Stroke mm	L mm	M $+0,10/-0,000$ mm	N $+0,10/-0,000$ mm	P $+0,000/-0,10$ mm	Q mm	S mm	V mm	W mm	X mm	Mass g
△OEM 1.0M CMS	25	162,1	3,58 $+0,13/0$	6,02 $+0,13/0$	9,5 $0/-0,3$	6,4	31,8	3,2	9,0	6,4	394

Notes: 1. Maximum sideload angle is 30°.

2. △= Non-standard lead time items, contact Enidine.

Adjustable Series Hydraulic Shock Absorbers

OEM Small Bore Series

Technical Data

OEM 1.15M → (LR)OEM 1.2M Series

Standard

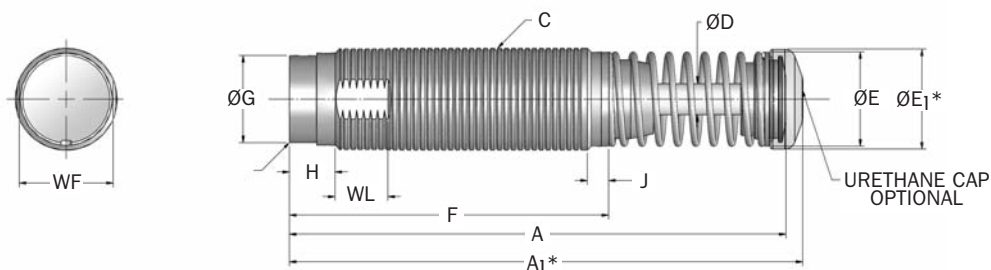

*Note: A₁ and E₁ apply to urethane striker cap accessory.

Catalog No./ Model	(S) Stroke mm	Optimal Velocity Range m/s	E _T Max. Nm/c	E _T C Max. Nm/hr	F _P Max. Reaction Force N	Nominal Coil Spring Force		F _D Max. Propelling Force N	Mass g
						Extended N	Compressed N		
△OEM 1.15M x 1	25,0	0,3-3,30	195,0	75 700	11 120	56,0	89,0	2 220	482
△(LR)OEM 1.15M x 1	25,0	0,08-2,0	195,0	75 700	11 120	56,0	89,0	3 335	482
△OEM 1.15M x 2	50,0	0,3-3,30	385,0	98 962	11 120	31,0	89,0	2 220	708
△(LR)OEM 1.15M x 2	50,0	0,8-2,0	385,0	98 962	11 120	31,0	89,0	3 335	708
OEM 1.25M x 1	25,0	0,3-3,30	195,0	91 000	11 120	56,0	89,0	2 220	567
(LR)OEM 1.25M x 1	25,0	0,8-2,0	195,0	91 000	11 120	56,0	89,0	3 335	567
OEM 1.25M x 2	50,0	0,3-3,30	385,0	111 400	11 120	31,0	89,0	2 220	737
(LR)OEM 1.25M x 2	50,0	0,8-2,0	385,0	111 400	11 120	31,0	89,0	3 335	737

Catalog No./Model	A mm	A ₁ mm	C mm	D mm	E mm	E ₁ mm	F mm	G mm	H mm	J mm	WF mm	WL mm
△(LR)OEM 1.15M x 1	150,0	155,5	M33 x 1,5	9,5	29,0	30,5	97,0	28,0	14,0	5,3	30,0	16,0
△(LR)OEM 1.15M x 2	217,0	222,0	M33 x 1,5	9,5	29,0	30,5	138,0	28,0	14,0	5,3	30,0	16,0
(LR)OEM 1.25M x 1	150,0	155,5	M36 x 1,5	9,5	29,0	30,5	97,0	28,0	14,0	5,3	33,0	16,0
(LR)OEM 1.25M x 2	217,0	222,0	M36 x 1,5	9,5	29,0	30,5	138,0	28,0	14,0	5,3	33,0	16,0

- Notes: 1. All shock absorbers will function satisfactorily at 5% of their maximum rated energy per cycle. If less than 5%, a smaller model should be specified.
 2. For mounting accessories, see pages 25-26.
 3. Urethane striker caps are available as accessories for models OEM 1.15M x 1 to OEM 1.25M x 2.
 4. △ = Non-standard lead time items, contact Enidine.

Urethane Striker Cap (USC)

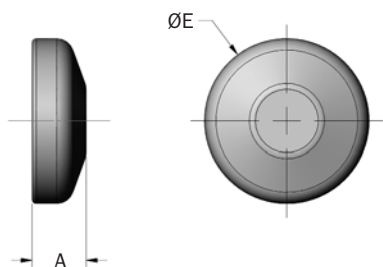

Catalog No./ Model	Part Number	Model Ref	A mm	E mm	Mass g
UC 8609	C98609079	(LR)OEM 1.15/1.25M	10,0	30,5	6

OEM 1.15M → OEM 1.25M Series

Jam Nut (JN)

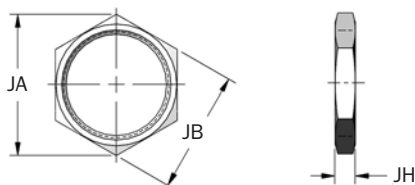

Catalog No./ Model	Part Number	Model Ref	JA mm	JB mm	JH mm	Mass g
JN M33 x 1.5	J28609035	(LR)OEM 1.15M	47,3	41,0	6,4	27
JN M36 x 1.5	J23164035	(LR)OEM 1.25M	47,3	41,0	6,4	27

Stop Collar (SC)

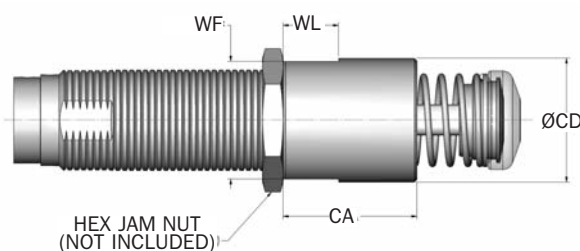

Catalog No./ Model	Part Number	Model Ref	CA mm	CD mm	WF mm	WL mm	Mass g
⊗ SC M33 x 1.5	M930290171	OEM 1.15M	44,5	38,1	30,0	16,0	215
⊗ SC M36 x 1.5	M930285171	OEM 1.25M	63,5	43,0	41,0	18,0	210
⊗ SC M25 x 2 x 1.56	M930288171	HP 110 MC	50,8	38,0	32,0	15,0	215
⊗ SC M25 x 1.5 x 1.56	M931291171	HP 110 MF	50,8	38,0	32,0	15,0	215

Notes: 1. *Do not use with urethane striker cap.

2. ⊗ Non-standard lead time items, contact Enidine.

Rectangular Flange (RF)

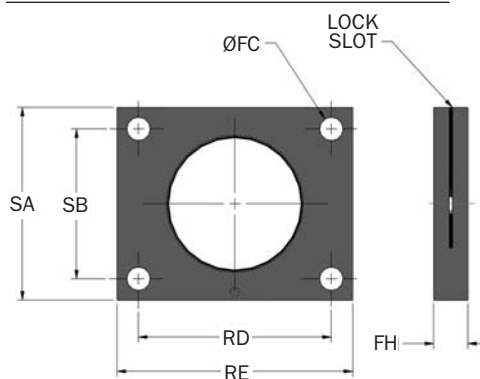

Catalog No./ Model	Part Number	Model Ref	FC mm	FH mm	RD mm	RE mm	SA mm	SB mm	Size mm	Mass g
RF M33 x 1.5	N121049141	(LR)OEM 1.15M	5,5	9,5	41,3	50,8	44,5	28,6	M5	30
RF M36 x 1.5	N121293141	(LR)OEM 1.25M	5,5	9,5	41,3	58,8	44,5	28,6	M5	30

Adjustable Series Hydraulic Shock Absorbers

OEM Small Bore Series

OEM 1.15M → OEM 1.25M Series

Accessories

Clevis Mount

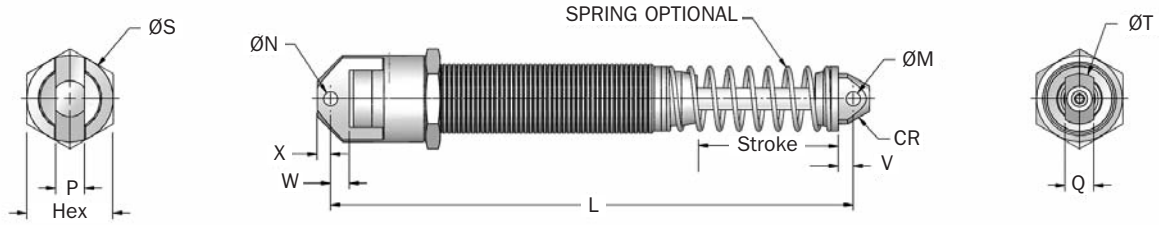

Catalog No./Model	S Stroke mm	L mm	M mm	N mm	P mm	Q mm	S mm	T mm	V mm	W mm	X mm	CR mm	Mass g
△(LR)OEM 1.15 x 1 CM (S)	25	163,6	6,02 +0,13/0	6,02 +0,13/0	12,7 0/-0,3	12,7 0/-0,3	38,1	22,3	6,0	8,3	6,0	10,0	725
△(LR)OEM 1.15 x 2 CM (S)	50	230,4	6,02 +0,13/0	6,02 +0,13/0	12,7 0/-0,3	12,7 0/-0,3	38,1	22,3	6,0	8,3	6,0	10,0	861
△(LR)OEM 1.25 x 1 CM (S)	25	163,6	6,02 +0,13/0	6,02 +0,13/0	12,7 0/-0,3	12,7 0/-0,3	38,1	22,3	6,0	8,3	6,0	10,0	725
△(LR)OEM 1.25 x 2 CM (S)	50	230,4	6,02 +0,13/0	6,02 +0,13/0	12,7 0/-0,3	12,7 0/-0,3	38,1	22,3	6,0	8,3	6,0	10,0	861

Notes: 1. "S" designates model is supplied with spring.
 2. △= Non-standard lead time items, contact Enidine.

Flange Foot Mount

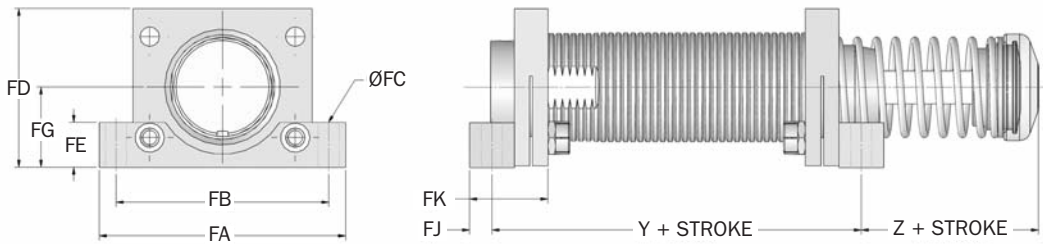

Catalog No./Model	Part Number	Model Ref	Y mm	Z mm	FA mm	FB mm	FC mm	FD mm	FE mm	FG mm	FJ mm	FK mm	Bolt Size mm	Mass g
FM M33 x 1.5	2F21049306	(LR)OEM 1.15M	56,6	31,8	70,0	60,3	6,0	44,5	12,7	22,7	6,4	22,2	M5	100
FM M36 x 1.5	2F21293306	(LR)OEM 1.25M	56,6	31,8	70,0	60,3	6,0	44,5	12,7	22,7	6,4	22,2	M5	100

Adjustable Series Hydraulic Shock Absorbers

OEMXT Mid-Bore Series

OEMXT 3/4 → (LR)OEMXT 1.5M Series

Standard

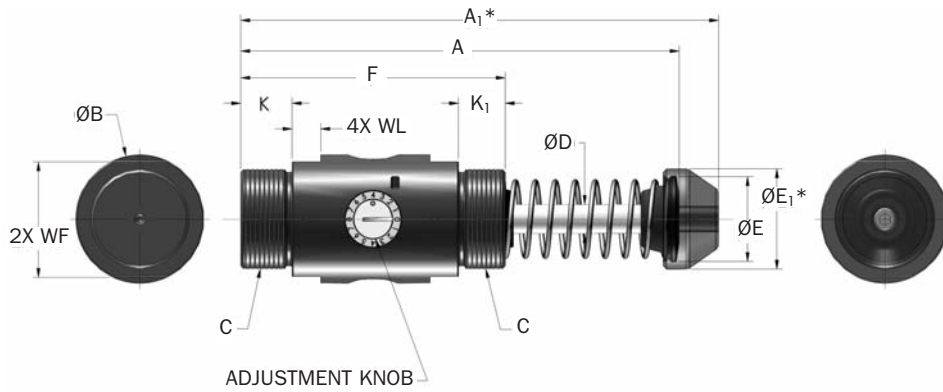

*Note: A_1 and E_1 apply to urethane striker cap accessory.

Catalog No./Model	(S) Stroke mm	Optimal Velocity Range m/s	E_T Max. Nm/c	E_{TC} Max. Nm/hr	F_p Max. Reaction Force N	Nominal Coil Spring Force		F_D Max. Propelling Force N	Mass Kg
						Extended N	Compressed N		
OEMXT 3/4 x 1	25,0	0,3-3,5	425	126 000	20 000	48	68	2 890	1,2
(LR)OEMXT 3/4 x 1	25,0	0,08-1,3	425	126 000	20 000	48	68	6 660	1,2
OEMXT 3/4 x 2	50,0	0,3-3,5	850	167 000	20 000	29	68	2 890	1,7
(LR)OEMXT 3/4 x 2	50,0	0,08-1,3	850	167 000	20 000	48	85	6 660	1,7
OEMXT 3/4 x 3	75,0	0,3-3,5	1 300	201 000	20 000	29	85	2 890	2,1
OEMXT 1.5M x 1	25,0	0,3-3,5	425	126 000	20 000	48	68	2 890	1,2
(LR)OEMXT 1.5M x 1	25,0	0,08-1,3	425	126 000	20 000	48	68	6 660	1,2
OEMXT 1.5M x 2	50,0	0,3-3,5	850	167 000	20 000	29	68	2 890	1,7
(LR)OEMXT 1.5M x 2	50,0	0,08-1,3	850	167 000	20 000	48	85	6 660	1,7
OEMXT 1.5M x 3	75,0	0,3-3,5	1 300	201 000	20 000	29	85	2 890	2,1

Catalog No./Model	C Thread	A mm	A_1 mm	B mm	D mm	E mm	E_1 mm	F mm	K mm	K_1 mm	WF mm	WL mm
(LR)OEMXT 3/4 x 1	1 3/4 - 12 UN	144	162	58	13	38	44	92	32	32	40,5	19
(LR)OEMXT 3/4 x 2	1 3/4 - 12 UN	195	213	58	13	38	44	118	45	45	40,5	19
(LR)OEMXT 3/4 x 3	1 3/4 - 12 UN	246	264	58	13	38	44	143	57	57	40,5	19
(LR)OEMXT 1.5M x 1	M42 x 1,5	144	162	58	13	38	44	92	32	32	40,5	19
(LR)OEMXT 1.5M x 2	M42 x 1,5	195	213	58	13	38	44	118	45	45	40,5	19
(LR)OEMXT 1.5M x 3	M42 x 1,5	246	264	58	13	38	44	143	57	57	40,5	19

Adjustable Series Hydraulic Shock Absorbers

OEMXT Mid-Bore Series

OEMXT 3/4 → (LR)OEMXT 1.5M Series

Accessories

Clevis Mount

Adjustable Series

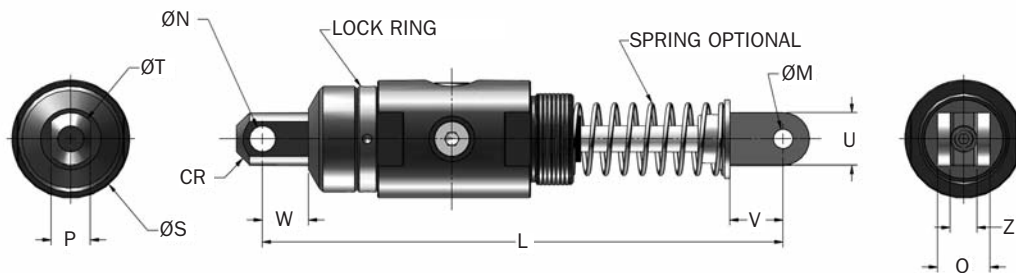

Catalog No./Model	(S) Stroke mm	L mm	M mm	N mm	P mm	Q mm	S mm	T mm	U mm	V mm	W mm	Z mm	CR mm	Mass kg
△(LR)OEMXT 3/4 x 1 CM (S)	25	199,0	9,60	12,70 +0,25/0	19,0 +0,25/0	25,4 0/-0,3	51,0	25,4	25,0	26,0	22,0	12,9	14,3 +0,5/-0	1,59
△(LR)OEMXT 1.5M x 1 CM (S)	25	199,0	9,60	12,70 +0,25/0	19,0 +0,25/0	25,4 0/-0,3	51,0	25,4	25,0	26,0	22,0	12,9	14,3 +0,5/-0	1,59
△(LR)OEMXT 3/4 x 2 CM (S)	50	250,0	9,60	12,70 +0,25/0	19,0 +0,25/0	25,4 0/-0,3	51,0	25,4	25,0	26,0	22,0	12,9	14,3 +0,5/-0	1,7
△(LR)OEMXT 1.5M x 2 CM (S)	50	250,0	9,60	12,70 +0,25/0	19,0 +0,25/0	25,4 0/-0,3	51,0	25,4	25,0	26,0	22,0	12,9	14,3 +0,5/-0	1,7
△OEMXT 3/4 x 3 CM (S)	75	300,0	9,60	12,70 +0,25/0	19,0 +0,25/0	25,4 0/-0,3	51,0	25,4	25,0	26,0	22,0	12,9	14,3 +0,5/-0	1,95
△OEMXT 1.5M x 3 CM (S)	75	300,0	9,60	12,70 +0,25/0	19,0 +0,25/0	25,4 0/-0,3	51,0	25,4	25,0	26,0	22,0	12,9	14,3 +0,5/-0	1,95

Notes: 1. "S" designates model is supplied with spring.
2. △= Non-standard lead time items, contact Enidine.

Flange Foot Mount

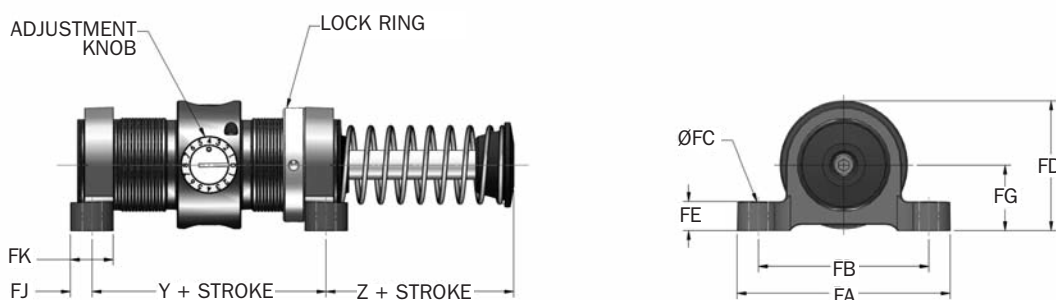

Catalog No./Model	Part Number	Model Ref	Y mm	Z mm	FA mm	FB mm	FC mm	FD mm	FE mm	FG mm	FJ mm	FK mm	Size	Bolt Mass g
FM 1 3/4-12	2FE2940	(LR)OEM 3/4	60,5	26,9	95,3	76,2	8,6	55,0	12,7	29,5	9,7	19,1	M8	370
FM M42 x 1,5	2F2940	(LR)OEM 1.5M	60,5	26,9	95,3	76,2	8,6	55,0	12,7	29,5	9,7	19,1	M8	370

OEMXT 1 1/8 → (LR)OEMXT 2.0M Series

Standard

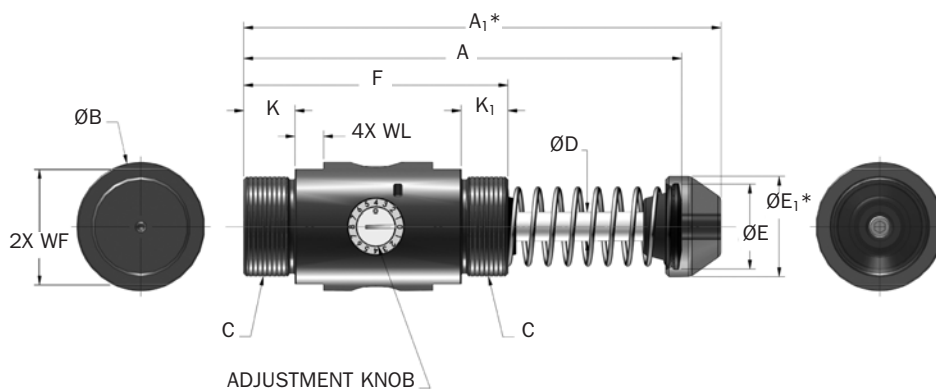

*Note: A₁ and E₁ apply to urethane striker cap accessory.

Catalog No./Model	(S) Stroke mm	Optimal Velocity Range m/s	E _T Max. Nm/c	E _T C Max. Nm/hr	F _p Max. Reaction Force N	Nominal Coil Spring Force		F _D Max. Propelling Force N	Mass Kg
						Extended N	Compressed N		
Δ LROEMXT 1 1/8 x 1	25,0	0,08-1,35	1 130	226 000	51 000	115	155	17 760	2,1
OEMXT 1 1/8 x 2	50,0	0,3-3,5	2 260	271 000	51 000	75	155	6 660	3,6
LROEMXT 1 1/8 x 2	50,0	0,08-1,35	2 260	271 000	51 000	75	155	17 760	3,6
OEMXT 1 1/8 x 4	100,0	0,3-3,5	4 520	362 000	51 000	70	160	6 660	4,9
OEMXT 1 1/8 x 6	150,0	0,3-3,5	6 780	421 000	51 000	90	284	6 660	6,4
Δ LROEMXT 2.0M x 1	25,0	0,08-1,35	1 130	226 000	51 000	115	155	17 760	2,1
OEMXT 2.0M x 2	50,0	0,3-3,5	2 260	271 000	51 000	75	155	6 660	3,6
LROEMXT 2.0M x 2	50,0	0,08-1,35	2 260	271 000	51 000	75	155	17 760	3,6
OEMXT 2.0M x 4	100,0	0,3-3,5	4 520	362 000	51 000	70	160	6 660	4,9
OEMXT 2.0M x 6	150,0	0,3-3,5	6 780	421 000	51 000	90	284	6 660	6,4

Note: **Δ** = Non-standard lead time items, contact Enidine.

Catalog No./Model	C	A mm	A ₁ mm	B mm	D mm	E mm	E ₁ mm	F mm	K mm	K ₁ mm	WF mm	WL mm
Δ LROEMXT 1 1/8 x 1	2 1/2 - 12 UN	175	192	77	19	50	57	114	38	38	61,5	19
LROEMXT 1 1/8 x 2	2 1/2 - 12 UN	226	243	77	19	50	57	140	51	51	61,5	19
OEMXT 1 1/8 x 4	2 1/2 - 12 UN	328	345	77	19	50	57	191	76	76	61,5	19
OEMXT 1 1/8 x 6	2 1/2 - 12 UN	456	473	77	19	50	57	241	76	76	61,5	19
Δ LROEMXT 2.0M x 1	M64 x 2,0	175	192	77	19	50	57	114	38	38	61,5	19
(LR)OEMXT 2.0M x 2	M64 x 2,0	226	243	77	19	50	57	140	51	51	61,5	19
OEMXT 2.0M x 4	M64 x 2,0	328	345	77	19	50	57	191	76	76	61,5	19
OEMXT 2.0M x 6	M64 x 2,0	456	473	77	19	50	57	241	76	76	61,5	19

Note: **Δ** = Non-standard lead time items, contact Enidine.

Clevis Mount

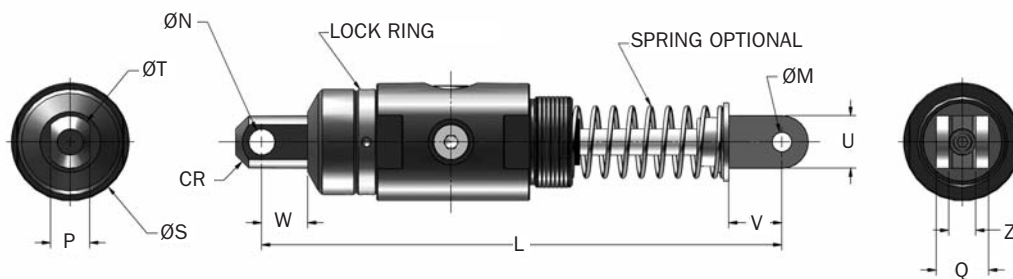

Catalog No./Model	(S) Stroke mm	L mm	M mm	N mm	P mm	Q mm	S mm	T mm	U mm	V mm	W mm	Z mm	CR mm	Mass kg
△(LR)OEMXT 1 1/8 x 2 CM (S)	50	306,0	19,07 +0,25/0	19,07 +0,25/0	31,7 0/-0,3	16,0	73,0	38,0	38,0	36,0	26,0	38,0 +0,5/0,0	23,0	5,30
△(LR)OEMXT 2.0M x 2 CM (S)	50	306,0	19,07 +0,25/0	19,07 +0,25/0	31,7 0/-0,3	16,0	73,0	38,0	38,0	36,0	26,0	38,0 +0,5/0,0	23,0	5,30
△OEMXT 1 1/8 x 4 CM (S)	100	408,0	19,07 +0,25/0	19,07 +0,25/0	31,7 0/-0,3	16,0	73,0	38,0	38,0	36,0	26,0	38,0 +0,5/0,0	23,0	6,08
△OEMXT 2.0M x 4 CM (S)	100	408,0	19,07 +0,25/0	19,07 +0,25/0	31,7 0/-0,3	16,0	73,0	38,0	38,0	36,0	26,0	38,0 +0,5/0,0	23,0	6,08
△OEMXT 1 1/8 x 6 CM (S)	150	537,0	19,07 +0,25/0	19,07 +0,25/0	31,7 0/-0,3	16,0	73,0	38,0	38,0	36,0	26,0	38,0 +0,5/0,0	23,0	7,39
△OEMXT 2.0M x 6 CM (S)	150	537,0	19,07 +0,25/0	19,07 +0,25/0	31,7 0/-0,3	16,0	73,0	38,0	38,0	36,0	26,0	38,0 +0,5/0,0	23,0	7,39

Notes: 1. "S" designates model is supplied with spring.
2. △ = Non-standard lead time items, contact Enidine.

Flange Foot Mount

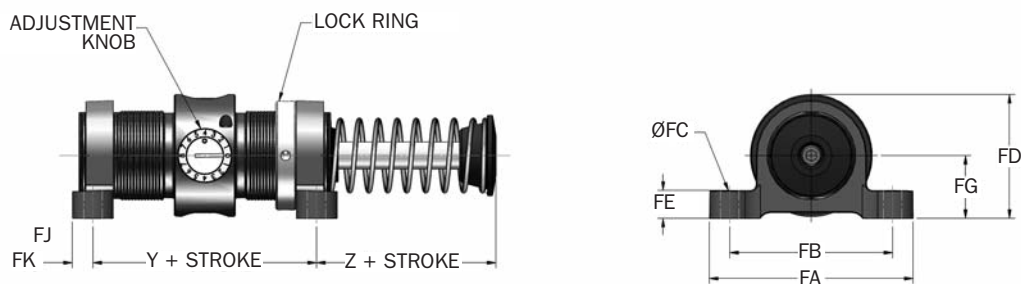

Catalog No./Model	Part Number	Model Ref	Y mm	Z mm	FA mm	FB mm	FC mm	FD mm	FE mm	FG mm	FJ mm	FK mm	Bolt Size mm	Mass kg	Notes
FM 2 1/2 x 12	2FE3010	(LR)OEM 1 1/8	76,2	39,6	143,0	124,0	10,4	89,7	16,0	44,5	11,2	22,4	M10	1.08	1
FM M64 x 2	2F3010	(LR)OEM 2.0M	76,2	39,6	143,0	124,0	10,4	89,7	16,0	44,5	11,2	22,4	M10	1.08	2

Note: 1. OEM 1 1/8 x 6 'Z' dimension is 68,3 mm.
2. OEM 2.0M x 6 'Z' dimension is 68,3 mm.

Adjustable Series Hydraulic Shock Absorbers

OEM Large-Bore Series

Technical Data

OEM 3.0M → OEM 4.0M Series

Standard

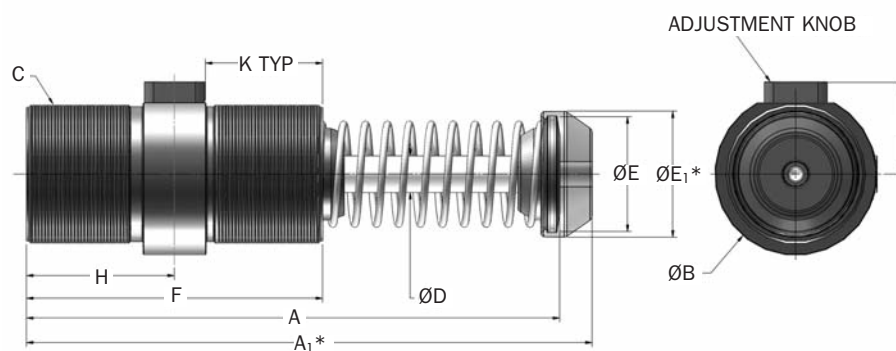

*Note: A₁ and E₁ apply to urethane striker cap accessory.

Catalog No./Model	(S) Stroke mm	Optimal Velocity Range m/s	E _T Max. Nm/c	E _T C Max. Nm/hr	F _p Max. Reaction Force N	Nominal Coil Spring Force		F _D Max. Propelling Force N	Mass Kg
						Extended N	Compressed N		
OEM 3.0M x 2	50	0,3-4,3	2 300	372 000	67 000	110	200	12 000	7,0
OEM 3.0M x 3.5	90	0,3-4,3	4 000	652 000	67 000	110	200	12 000	9,1
OEM 3.0M x 5	125	0,3-4,3	5 700	933 000	67 000	71	200	12 000	10,9
OEM 3.0M x 6.5	165	0,3-4,3	7 300	1 215 000	67 000	120	330	12 000	13,6
OEM 4.0M x 2	50	0,3-4,3	3 800	1 503 000	111 000	225	290	21 000	15,0
OEM 4.0M x 4	100	0,3-4,3	7 700	1 808 000	111 000	155	290	21 000	18,2
OEM 4.0M x 6	150	0,3-4,3	11 500	2 102 000	111 000	135	310	21 000	20,0
△OEM 4.0M x 8	200	0,3-4,3	15 400	2 407 000	111 000	180	355	21 000	30,0
△OEM 4.0M x 10	250	0,3-4,3	19 200	2 712 000	111 000	135	355	21 000	33,0

Note: △ = Non-standard lead time items, contact Enidine.

Catalog No./Model	A mm	A ₁ mm	B mm	C	D mm	E mm	E ₁ mm	F mm	H mm	J mm	K mm
OEM 3.0M x 2	245	265	98	M85 x 2.0	22	69	76	140	70	58	51
OEM 3.0M x 3.5	323	343	98	M85 x 2.0	22	69	76	179	90	58	71
OEM 3.0M x 5	399	419	98	M85 x 2.0	22	69	76	217	109	58	71
OEM 3.0M x 6.5	494	514	98	M85 x 2.0	22	81	81	256	128	58	71
OEM 4.0M x 2	313	335	127	M115 x 2.0	35	88	95	203	102	74	80
OEM 4.0M x 4	414	436	127	M115 x 2.0	35	88	95	254	127	74	105
OEM 4.0M x 6	516	538	127	M115 x 2.0	35	88	95	305	153	74	108
△OEM 4.0M x 8	643	665	127	M115 x 2.0	35	88	95	356	178	74	108
△OEM 4.0M x 10	745	767	127	M115 x 2.0	35	88	95	406	203	74	108

Notes: 1. All shock absorbers will function satisfactorily at 5% of their maximum rated energy per cycle. If less than 5%, a smaller model should be specified.

2. For mounting accessories, see pages 32.

3. Rear flange mounting of OEM 3.0M x 6.5, OEM 4.0M x 8 and OEM 4.0M x 10 models not recommended when mounting horizontally.

4. △ = Non-standard lead time items, contact Enidine.

Adjustable Series Hydraulic Shock Absorbers

OEM Large-Bore Series

OEM 3.0M → OEM 4.0M Series

Accessories

Clevis Mount

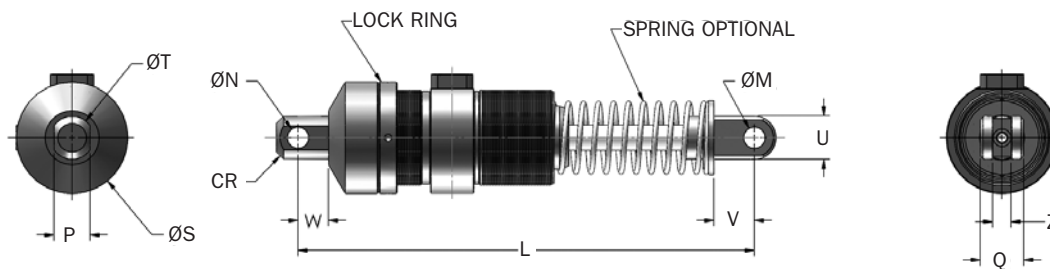

Catalog No./Model	(S) Stroke mm	L mm	M mm	N mm	P mm	Q mm	S mm	T mm	U mm	V mm	W mm	Z mm	CR mm	Mass kg
△OEM 3.0M x 2 CM (S)	50	325,0	19,07 +0,25/0	19,07 +0,25/0	31,7 0/-0,3	38,0	98,0	38,1	38,1	36,0	26,0	16,0 +0,5/0	23,0	8,66
△OEM 3.0M x 3.5 CM (S)	90	402,0	19,07 +0,25/0	19,07 +0,25/0	31,7 0/-0,3	38,0	98,0	38,1	38,1	36,0	26,0	16,0 +0,5/0	23,0	10,70
△OEM 3.0M x 5 CM (S)	125	479,0	19,07 +0,25/0	19,07 +0,25/0	31,7 0/-0,3	38,0	98,0	38,1	38,1	36,0	26,0	16,0 +0,5/0	23,0	12,52
△OEM 3.0M x 6.5 CM (S)	165	574,0	19,07 +0,25/0	19,07 +0,25/0	31,7 0/-0,3	38,0	98,0	38,1	38,1	36,0	26,0	16,0 +0,5/0	23,0	15,24
△OEM 4.0M x 2 CM (S)	50	432,0	25,42 +0,25/0	25,42 +0,25/0	38,1 0/-0,3	90,5	127,0	57,2	51,0	51,0	44,0	38,2 +0,5/0	35,0	19,23
△OEM 4.0M x 4 CM (S)	100	533,0	25,42 +0,25/0	25,42 +0,25/0	38,1 0/-0,3	90,5	127,0	57,2	51,0	51,0	44,0	38,2 +0,5/0	35,0	22,41
△OEM 4.0M x 6 CM (S)	150	635,0	25,42 +0,25/0	25,42 +0,25/0	38,1 0/-0,3	90,5	127,0	57,2	51,0	51,0	44,0	38,2 +0,5/0	35,0	24,22
△OEM 4.0M x 8 CM (S)	200	762,0	25,42 +0,25/0	25,42 +0,25/0	38,1 0/-0,3	90,5	127,0	57,2	51,0	51,0	44,0	38,2 +0,5/0	35,0	34,20
△OEM 4.0M x 10 CM (S)	250	864,0	25,42 +0,25/0	25,42 +0,25/0	38,1 0/-0,3	90,5	127,0	57,2	51,0	51,0	44,0	38,2 +0,5/0	35,0	37,37

Notes: 1. "S" indicates model is supplied with spring.
2. △ = Non-standard lead time items, contact Enidine.

Flange Foot Mount

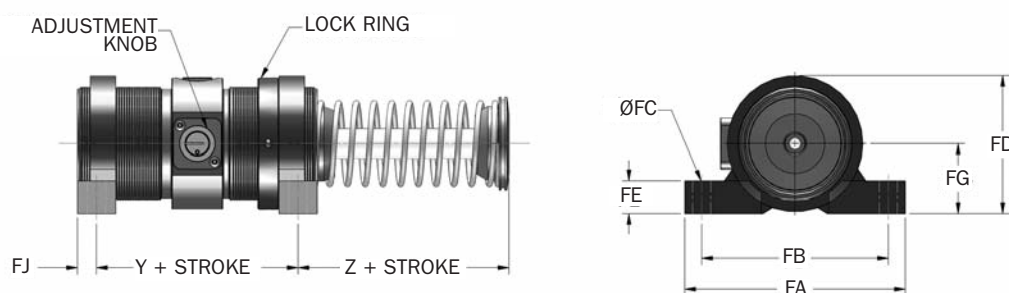

Catalog No./Model	Part Number	Model Ref	J mm	Y mm	Z mm	FA mm	FB mm	FC mm	FD mm	FE mm	FG mm	FJ mm	FK mm	Bolt Size mm	Mass kg	Notes
FM M85 x 2	2F3330	OEM 3.0M	58	81,0	59,0	165,0	139,7	13,5	103,0	25,4	52,3	14,1	28,7	M12	1 984	1
FM M115 x 2	2F3720	OEM 4.0M	74	190,5	37,0	203,2	165,0	16,8	149,4	38,0	79,5	16,0	50,8	M16	3 900	2

Notes: 1. OEM 3.0M x 6,5, Z dimension is 77,7mm.
2. OEM 4.0M x 8 and 4.0M x 10M, Z dimension is 62,0mm.
3. For rear foot mount, dimension FJ is 22,4mm.

Stop Collar (SC)

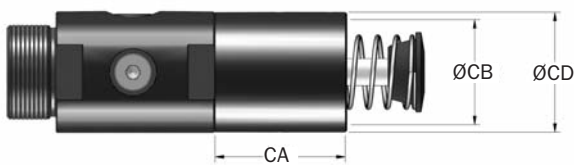
(LR)OEMXT $\frac{3}{4}$ → (LR)OEMXT 2.0M

Catalog No./ Model	Part Number	Model Ref	CA mm	CB mm	CD mm	Mass g
△ SC M2 1/2 - 12*	8KE2940	(LR)OEMXT $\frac{3}{4}$	49,0	49,0	56,5	340
△ SC M2 1/2 - 12 x 2	8KE3010	(LR)OEMXT 1 1/8 x 2 & 4	63,0	65,0	76,0	652
△ SC M2 1/2 - 12 x 6	8KE3012	(LR)OEMXT 1 1/8 x 6	93,0	65,0	76,0	936
△ SC M42 x 1.5 x 1	8K2940	(LR)OEMXT 1.5M x 1	62,0	49,0	56,0	397
△ SC M42 x 1.5 x 2	8K2941	(LR)OEMXT 1.5M x 2	75,0	49,0	56,0	539
△ SC M42 x 1.5 x 3	8K2942	OEMXT 1.5M x 3	87,0	49,0	56,0	652
△ SC M64 x 2 x 2	M93010057	(LR)OEMXT 2.0M x 2	89,0	65,0	76,0	936
△ SC M64 x 2 x 4	M93011057	OEMXT 2.0M x 4	114,0	65,0	76,0	1 191
△ SC M64 x 2 x 6	M93012057	OEMXT 2.0M x 6	143,0	65,0	76,0	1 475

Notes: 1. * Do not use with urethane striker cap.

2. △ = Non-standard lead time items, contact Enidine.

Lock Ring (LR)

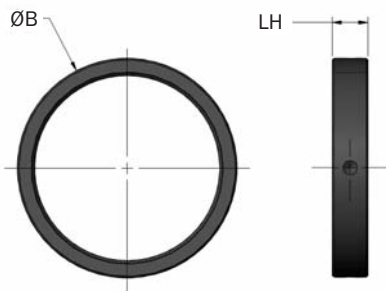

Catalog No./ Model	Part Number	Model Ref	B mm	LH mm	Mass g
LR 1 3/4 - 12	F8E2940049	(LR)OEMXT $\frac{3}{4}$	50,8	9,6	85
LR 2 1/2 - 12	F8E3010049	(LR)OEMXT 1 1/8	73,0	12,7	114
LR M42 x 1.5	F82940049	(LR)OEMXT 1.5M	50,8	9,6	85
LR M64 x 2	F83010049	(LR)OEMXT 2.0M	73,0	12,7	114
LR M85 x 2	F83330049	(LR)OEM 3.0M	98,2	16,0	226
LR M115 x 2	F83720049	(LR)OEM 4.0M	126,7	22,4	397

Square Flange (SF)

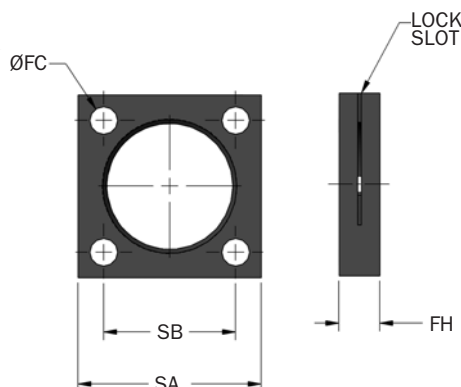

Catalog No./ Model	Part Number	Model Ref	FC mm	FH mm	SA mm	SB mm	Bolt Size mm	Mass g
SF 1 3/4 - 12	M4E2940129	(LR)OEMXT $\frac{3}{4}$	8,6	12,7	57,2	41,4	M8	140
SF 2 1/2 - 12	M4E3010129	(LR)OEMXT 1 1/8	10,4	15,7	90,0	89,0	M10	570
SF M42 x 1.5	M42940129	(LR)OEMXT 1.5M	8,6	12,7	57,2	41,4	M8	140
SF M64 x 2	M43010141	(LR)OEMXT 2.0M	10,4	15,7	90,0	89,0	M10	570
SF M85 x 2	M43330141	OEM 3.0M	13,5	19,0	101,6	76,2	M13	680
SF M115 x 2	M43720141	OEM 4.0M	16,5	25,4	139,7	111,3	M16	1 590

Adjustable Series Hydraulic Shock Absorbers

OEM Mid-Bore/Large-Bore Accessories

Accessories

Rectangular Flange (RF)

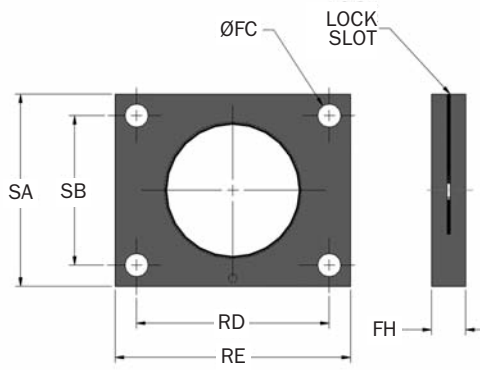

Catalog No./ Model	Part Number	Model Ref	FC mm	FH mm	RD mm	RE mm	SA mm	SB mm	Bolt Size mm	Mass g
RF 1 3/4 -12	M5E2940129	(LR)OEMXT 3/4	8,6	12,7	60,5	76,2	57,2	41,4	M8	260
RF M42 x 1.5	M52940129	(LR)OEMXT 1.5M	8,6	12,7	60,5	76,2	57,2	41,4	M8	260
RF M85 x 2	M53330129	OEM 3.0M	13,5	19,1	101,6	127,0	101,6	76,2	M13	1 040

Stop Bar Kit

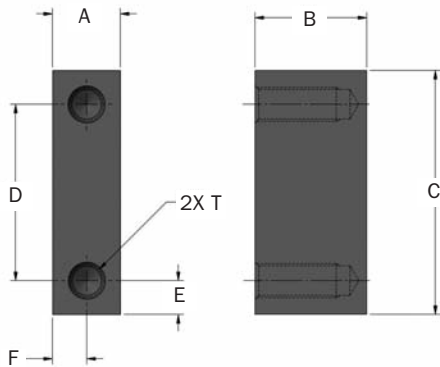

Kit Part Number	Model Ref	A mm	B mm	C mm	D mm	E mm	F mm	T	Bolt Size mm	Mass g
ΔT52940300	OEMXT 3/4	16,0	26,2	57,2	41,4	7,9	8,1	5/16 - 24 UNF x 18 mm DEEP	5/16	173
ΔT53010300	OEMXT 1 1/8	12,7	36,1	88,9	69,9	9,7	8,1	3/8 - 24 UNF x 18 mm DEEP	3/8	298

Notes: 1. Kit includes 2 Stop Bars, Rectangular Flange for OEMXT 3/4 and 1.5M, Square Flange for 1 1/8 and 2.0M and Lock Ring.
 2. Δ = Non-standard lead time items, contact Enidine.

Urethane Striker Cap (UC)

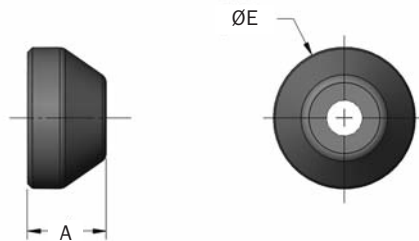

Catalog No./ Model	Part Number	Model Ref	A mm	E ₁ mm	Mass g
UC 2940	C92940079	(LR)OEMXT 3/4	24,5	44,5	14
UC 3010	C93010079	(LR)OEMXT 1 1/8	24,1	57,0	23
UC 2940	C92940079	(LR)OEMXT 1.5M	24,5	44,5	14
UC 3010	C93010079	(LR)OEMXT 2.0M	24,1	57,0	23
UC 3330	C93330079	OEM 3.0M	31,4	76,0	85
UC 3720	C93720079	OEM 4.0M	37,5	95,0	170

Note: For complete shock absorber dimension with urethane striker cap, refer to engineering data, pages 27-31.

Stop Collar With Flange (SCF)

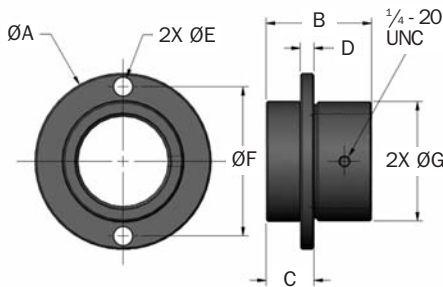

Catalog No./ Model	Part Number	Model Ref	A mm	B mm	C ±.002 mm	D mm	E mm	F mm	G mm	Bolt Size mm	Mass g
ΔSCF 1 3/4 -12	M98640300	OEMXT 3/4	83	49,3	22,4	6,4	8,6	70	56	8	638
ΔSCF 2 1/2 -12	M98650300	OEMXT 1 1/8	108	63	25,4	9,7	8,6	89	75	8	1 238

Notes: 1. Locking set screw feature provided as standard.
 2. Δ = Non-standard lead time items, contact Enidine.